



# **Service Plan 2005-2007**

Jan. 30, 2004

The Honourable Richard Neufeld  
Minister of Energy and Mines  
Province of British Columbia

Minister:

On behalf of the Board of Directors and staff of the Columbia Basin Trust (CBT), I have the honour to submit for your approval the Service Plan for the year ending March 31<sup>st</sup>, 2005.

As mandated by the *Columbia Basin Trust Act* and the *Columbia Basin Management Plan*, the primary business of CBT is to invest the funds received through the *Columbia Basin Trust Act* and the subsequent *Financial Agreement* dated July 27<sup>th</sup>, 1995. There are four core business areas through which investments and expenditures are made, and activities carried out, namely:

- Investment of the Basin Fund to (a) protect the capital and (b) provide income to deliver benefits to the people of the region.
- Investment of the Legacy Fund in power projects in the region as part of a joint venture partnership with the Province of British Columbia.
- Delivery of benefits to the people of the region to foster social, environmental and economic well-being.
- Corporate services that provide for effective and efficient operations through planning, monitoring, accounting and evaluation activities as well as the provision of ongoing administration, information technology, communications and human resource services.

The CBT, using income from its investment programs, has delivered \$21.5 million in social, economic and environmental benefits to the region and has worked with and engaged the residents in its activities and decisions in a variety of ways in fulfilling its mandate over the past nine years of operation.

The corporation has built a strong regional foundation, which will serve it well in the years to come as it attempts to successfully manage the changes that will create significant challenges, namely:

- Organizational adjustments to the final outcomes of the core review process.
- Meeting Basin residents' priorities by developing and implementing a community capacity building approach to the Delivery of Benefits program.

There are several major challenges facing us in the year ahead with regard to the changes stemming from the *Columbia Basin Trust Amendment Act (Bill 79)*. It will be incumbent on the CBT to demonstrate that the organization remains committed to the *Columbia Basin Management Plan (CBMP)*, and through the *CBMP* remains accountable to the people of the Basin. The changes will also require diligence on the part of the board in terms of ensuring their deliberations continue to take into account the diversity of issues and communities in the Basin that historically have been well represented by the larger board. The board will also have to examine the roles and responsibilities of all current committees to ensure the smaller board is able to effectively distribute the workload.

On behalf of the Board of Directors and Staff, I thank you for your consideration of CBT's FY2005-2007 Service Plan.

Yours sincerely,



Josh Smienk  
Chairman of the Board of Directors  
Columbia Basin Trust

# TABLE OF CONTENTS

---

<i>Chair’s Letter to Minister</i> .....	1
<i>CEO Report</i> .....	3
<i>Corporate History and Overview</i> .....	4
<i>Governance</i> .....	5
<i>Core Business Area and Activities</i> .....	5
<i>Strategic Context</i> .....	6
<i>Planning and Operations Context</i> .....	7
<i>Strategic Direction</i> .....	10
<i>Strategic Area 1: Investment Program</i> .....	11
<i>Strategic Area 2: Delivery of Benefits</i> .....	13
<i>Strategic Area 3: Corporate Services</i> .....	15
<i>Alignment With Government’s Strategic Plan</i> .....	17
<i>Summary Financial Outlook</i> .....	18
<i>Appendix A: Organization Structure</i> .....	21
<i>Appendix B: CBTE Service Plan</i> .....	23

# CEO REPORT

---

The writing of the annual service plan is an opportunity to focus on the three years ahead, and an opportunity to reflect on the year still underway. This has been a busy year where much has been accomplished. We have continued to fulfill our commitments from last year's service plan and will have delivered another \$4M dollars in benefits through our Delivery of Benefits program. This brings our total to well over \$21M in delivered benefits to the region since we began six years ago. We continue to invest in businesses throughout the Basin, and by the end of fiscal 2003-2004 we will have over \$38M invested directly in the Basin. On the energy side, the beginning of construction on the Brilliant Expansion Project highlighted the current fiscal year. This project, slated for completion in the summer of 2006, will generate significant additional revenue for both the CBT and the provincial government.

In addition to the changes CBT faces resulting from the *CBT Amendment Act* which were addressed by the Chairman, CBT is looking forward to the upcoming consolidation of our own power activities, currently mandated to our subsidiary, CBT Energy, with those of Columbia Power Corporation ("CPC") into a single, wholly CBT-owned subsidiary. We will continue to operate as a crown agency with the Province and CBT each receiving fifty percent of the net income from power projects. CBT expects to earn cost savings through the consolidation of our power activities with those of CPC and the resulting consolidation of tasks presently undertaken by both CBT and CPC. As the consolidation will be ongoing over the next few months, CBT and CPC have each prepared Service Plans for the coming three fiscal years and anticipate that a single CBT Service Plan will be produced during fiscal year 2005. I wish to emphasize that consolidating two Crown agencies into one while maintaining separate and expert oversight for the power assets will improve CBT's ability to deliver benefits to Basin residents.

Residents have expressed concerns with regard to the role of advisory committees and the CBT's commitment to involving and engaging Basin residents in their deliberations and in the delivery of programs. We are deeply committed to engaging and involving Basin residents in our work and one of our major goals for the coming year is to identify new and additional ways to accomplish this. We will be working with existing sector advisory committees to develop strategies to reach out beyond our current advisors and to expand the opportunities for input into CBT and our planning and operations.

With the Delivery of Benefits program, we are developing a new structure and approach, which we believe will be more flexible and responsive. In developing the new model we have consulted broadly with advisory committees, professionals, board members, staff and delivery partners. The focus will be on working with communities, both geographic communities and communities of interest, to develop relationships and to come to understand the issues and challenges as perceived from the community perspective. The CBT sees its role as much more broad than simply that of a funding agency. We have a responsibility to take a broad view of how the CBT can add value in assisting communities to realize their goals. That could take the form of facilitation or convening people and organizations. That could take the form of networking and identifying other communities or resources that could help a community develop their plans to deal with a particular issue. That could take the form of introducing communities to other sources of funding, and that could take the form of supplying financial support to a particular project or program. No longer is it sufficient for the CBT to simply develop and implement programs. We need to also work with communities and to find real and concrete ways to live up to our Mission Statement "to support the efforts by the people of the Basin to create a legacy of social, economic and environmental well-being and to achieve greater self-sufficiency for present and future generations."

I am once again honoured to work with the committed volunteers and staff who make up the CBT family and look forward with anticipation to the challenging year ahead.



Don Johnston  
Chief Executive Officer

# CORPORATE HISTORY AND OVERVIEW

---

Canada and the United States were facing two major challenges in the Columbia Basin after the Second World War – the “untamed” Columbia River was causing periodic and sometimes devastating flooding, and an upswing in the economy increased the need for energy sources.

In 1964, Canada and the U.S. ratified the *Columbia River Treaty (CRT)*. The purpose of the CRT is to coordinate flood control and optimize potential electrical energy production in the Columbia River Basin in the United States and Canada. Under the CRT, Canada agreed to build three storage dams – Duncan (1968), Keenleyside (1969) and Mica (1975) – in the Canadian Columbia Basin. The CRT allowed for a fourth dam – Libby (1973) – to be built in the United States with a large portion of its reservoir in southeastern British Columbia.

In return for the storage of water, Canada is entitled to one half of the additional potential power generated at the American power plants on the Columbia River. The Province of B.C., which owns this “Canadian Entitlement of Downstream Benefits” sold the first 30 years of these benefits to a group of U.S. utilities for \$254M U.S. The Province is now receiving the Canadian Entitlement for the remaining 30 years of the CRT.

As a result of the CRT:

- 2,300 people along the Arrow Lakes and the Koochanusa, Duncan and Kinbasket reservoirs were displaced.
- Sixty thousand hectares (500 square kilometers) of high-value, valley-bottom land was flooded.
- Numerous First Nations’ archaeological and burial sites were submerged or buried.
- Areas that were critical to the cultural, economic and environmental well-being of the region were lost.

The region is still dealing with the on-going impacts from the rise and fall of water levels:

- Recreation on reservoirs is limited because of the large seasonal fluctuations of the water levels, thereby limiting potential economic development through tourism.
- Fish and wildlife species and populations are impacted by the loss of key habitat and this increases pressures on residual low elevation areas.
- Dust storms around reservoirs impact human health at times of low water.
- Transportation infrastructure in the region is more complex and difficult to maintain.
- Agriculture and forestry activities are limited due to the loss of fertile, low-elevation land.

By the early 1990’s, people of the Columbia Basin became aware that an opportunity for public involvement might present itself. The sale of the first 30 years of B.C.’s share of the downstream benefits through the CRT was about to expire. Residents of the region felt local people should be given more say in matters concerning environmental, economic and social health.

Leaders from First Nations, local communities and the Province of B.C. worked together on an agreement that recognizes the continuing impacts from the historical management of water in this region. In 1995, the CBT was formed with a unique mandate to support the efforts of the people of the Basin to create a legacy of social, economic and environmental well-being in the region most affected by the CRT.

Through a financial agreement with the Province of B.C., the CBT was endowed with \$295M, approximately five per cent of the downstream benefits owned by the Province of B.C. \$250M of the capital is to be invested in joint venture power projects with the Province of B.C., and \$45M as endowment capital. Under the financial agreement, the CBT also receives \$2M/year from the Province for operating costs for the years 1996 through 2010 (FY2011).

## GOVERNANCE

---

The CBT is a regional Crown corporation. A Board of twelve (12) Directors governs the CBT, with regional governments (i.e. five regional districts and the Ktunaxa Kinbasket Tribal Council) each nominating a minimum of one and a maximum of four directors and the Provincial government nominating six directors to the Lieutenant Governor for final decision and appointment. All directors must be Columbia Basin residents. These directors provide policy direction, in accordance with both the *Columbia Basin Trust Act* and the Columbia Basin Management Plan (CBMP), the latter developed through broad public consultation with Basin residents. The Chief Executive Officer, in turn, is responsible for operational matters, performance review, and evaluation.

In January 2004, the Ministry of Energy and Mines announced that, in the coming months, the CBT's power activities would be consolidated with those of CPC into a single 100 per cent CBT-owned subsidiary. The new subsidiary will maximize the value of and income from the power projects. An expert board of directors will govern the new subsidiary, and the CBT will appoint a majority of the new subsidiary's board.

Appendix A includes both an organization chart that highlights the functional areas and lines of responsibilities as they presently exist and an organization chart that highlights the structure of CBT once consolidation with CPC is complete.

## CORE BUSINESS AREAS AND ACTIVITIES

---

The primary business of the CBT is to invest the funds granted to it through the *Columbia Basin Trust Act* and the subsequent *Financial Agreement* dated July 27<sup>th</sup>, 1995. The Province of B.C. endowed CBT with capital of \$45M (the Basin Fund), and another \$250M (the Legacy Fund), payable in \$50M annual installments, commencing in 2001, to be invested in power projects in the region. An additional \$32M in sixteen annual installments of \$2M is provided for operating costs in the developmental years, the final payment to be made in FY2011.

There are four core business areas through which investments and expenditures are made, and activities carried out, namely:

- Investment of the Basin Fund to (a) protect the capital and (b) provide income to deliver benefits to the people of the region.
- Investment of the Legacy Fund in power projects in the region as part of a joint venture partnership with the Province of B.C.
- Delivery of benefits to the people of the region to foster social, environmental and economic well-being.

- Corporate services that provide for effective and efficient operations through planning, monitoring, accounting and evaluation activities as well as the provision of ongoing administration, information technology, communications and human resource services.

In each of these core business areas, the CBT performs a stewardship role protecting the public interest and ensuring due diligence and accountability of public funds. Table A provides an overview of this year's current staffing and funding for each of its business areas.

**Table A: Business Overview**

<b>Funding</b>	<b>Core Business Areas</b>	<b>Service Allocation</b>
Provincial government, investment in power projects \$50M per year to a total of \$250M \$26M paid in 2000 (half the book value of expansion rights for the Brilliant and Waneta dams)	Management of joint venture power investment activities (Number of FTEs to be determined in FY2005 upon consolidation of power activities with CPC)	\$50M per annum invested in power projects
\$45M endowment capital	Management of non-power investments (2 FTEs)	\$45M invested in region to industry standards Capital increased to \$52M to match inflation
Income from Power and Non-Power Investments	Delivery of benefits to region (9 FTEs)	\$3.75M per annum delivered in benefits to region
Provincial government contribution of \$2M for operations support Income from investment	Corporate Services: Administration, Planning, Information Technology, Monitoring and Evaluation, Communications, Accounting (15 FTEs)	Corporate operations \$3.4M

## **STRATEGIC CONTEXT**

---

### **VISION**

The Columbia Basin is a place where social, environmental and economic well-being is fostered, where collaborative relationships and partnerships exist among stakeholders and form the basis for social and economic activities, and where the economy is diverse, resilient and energized.

### **MISSION**

The CBT supports efforts by the people of the Basin to create a legacy of social, economic and environmental well-being and to achieve greater self-sufficiency for present and future generations.

### **VALUES**

A set of values governs the management and operations of CBT and consists of:

**Inclusiveness:**

- Include the people of the Basin in planning and decision-making.

**Collaboration:**

- Work with the public and other agencies and organizations.

**Respect for diversity:**

- Respect the history and diversity of the people and communities of the Basin.

**Responsibility:**

- Taking into account the Basin residents' economic, environmental, social and sustainability values, the CBT will openly and explicitly balance maximizing benefits and minimizing negative impacts.

## **PLANNING AND OPERATIONS CONTEXT**

---

The Columbia Basin, along with the rest of the province and the country, as well as globally, has been subject to forces of change. These changes have created both opportunities and challenges for the CBT that impact upon its ability to achieve the vision, goals and objectives as identified in this plan. The following outlines the external and internal forces and influences that affect the region and the work of CBT.

Appendix B, the CBT Energy Service Plan, contains more specific discussion regarding the planning and operations context of CBT's power activities and the upcoming consolidation of those activities with CPC.

### **External Environment**

As in previous Service Plans, the external challenges and opportunities with which CBT is faced, and that need to be accounted for in the formulation of strategies, can be categorized into the following factors:

- Economy
- Infrastructure
- Finance
- Fiscal pressures facing government
- Basin residents' perceptions and challenging expectations
- Balancing capacity building with fairness

### **Economy**

The main industries within the Columbia Basin are forestry and related businesses, tourism and mining. The forest and mining industries have been affected by world market factors. While the effect of terrorist activities on tourism seems to have diminished, SARS, Mad Cow Disease and the devastating fires of the summer of 2003 combined to greatly diminish tourism traffic to the Columbia Basin at the time of writing this Plan. These types of external, unanticipated crisis cannot be forecast. Economic challenges continue to present a problem with regard to good living wages, with a corresponding impact on businesses. If not addressed in terms of assisting with



continued diversification in business activity, labour market development and promotion of the region's advantages and assets, further losses in business activity, income and investment may be witnessed.

CBT is working with Basin businesses to seek opportunities to diversify Basin economies from the traditional reliance on primary industries.

### **Infrastructure**

In the rural, mountainous area that defines the Columbia Basin, communication technology infrastructure is expensive and the lack of it within the region acts as a barrier to the establishment of high technology industries. Difficult winter driving conditions, high passes and narrow roads also act as a barrier to business location and investment. Air transportation in the West Kootenays is unreliable for much of the year because of poor visibility. These factors can act to prohibit new business activity and increased tourist travel to the region.

Most Basin communities have a history of strong local governments, providing for basic infrastructure and lifestyle opportunities, which have attracted new residents to the Basin. CBT is working with telecommunications organizations to provide broadband Internet access to the Basin. Three community groups, working with the Columbia Mountain Open Network, and assisted by CBT, have been granted federal matching funding under the Broadband for Rural and Northern Development pilot projects (BRAND) to the sum of \$6M. CBT is also in discussion with the Cranbrook Airport Authority regarding the proposed expansion of the Cranbrook Airport.

### **Finance**

There remains a general reluctance on the part of traditional commercial lending institutions to lend money to new and expanding businesses in Southeastern B.C.

While CBT is able to somewhat offset this reality by making capital available to businesses in the Basin in cooperation with local financial institutions, we are limited both by the size of our investment pool, CBT's investment policy which includes preservation of the capital, and by current low interest rates. Investments are actively monitored to ensure we have a balanced portfolio with an appropriate risk profile, while still assisting businesses and commercial ventures to expand or maintain their operations.

### **Fiscal Pressures Facing Government**

The provincial government's fiscal priorities have resulted in changes to service delivery across B.C., including the Columbia Basin. While neither CBT's mandate nor its current income allow it to ameliorate the above, Basin residents nevertheless look to the CBT for solutions. The CBT must therefore manage this risk of public perception of responsibility through its advocacy, partnership building and outreach efforts.

While CBT is presented with the challenge of identifying its appropriate role in the region with regards to services that were once provided by other levels of government, it also has the opportunity to work with Basin communities, organizations and residents to re-examine traditional ways of meeting residents' needs and designing new ones. CBT is currently revising its delivery model to facilitate working with communities to build capacity as needed.

## **Basin Residents' Perceptions and Challenging Expectations**

Basin residents have become aware of CBT and as that awareness has grown so too have their perceptions and expectations of CBT. A commonly held perception is that CBT is purely a funding organization and this has implications on what CBT can/will do. In addition, their expectations of what can be done often exceed the currently limited resources of the organization and the expectations residents have may be contradictory in nature (people are attracted to the rural lifestyle but expect all amenities).

CBT is working to ensure Basin residents have a clear understanding of its abilities, resources and limitations.

## **Balancing Capacity Building with Fairness**

Basin communities include urban, unincorporated and rural areas and are not homogeneous. The implications of this diversity are substantial in the context of CBT moving toward a capacity building approach to program and service delivery. The residents of the different communities have expectations that they will receive a fair share of CBT funding compared to the other communities and the idea of sharing among communities equally may conflict with a capacity building approach.

CBT is changing the organizational focus from strategic program delivery to working with communities to build capacity and identify community priorities and projects in which CBT can participate.

## **Internal Environment**

The key challenges and opportunities within CBT's internal environment that influence planning include:

- Successfully managing change.
- Basin Fund tensions.
- Meeting challenges inherent in our delivery model, mandate and working in a rural region.

## **Successfully Manage Change**

CBT is facing a number of very significant changes over the time period of this service plan. One of its key challenges will be to successfully manage these changes. The changes also constitute the key strategic issues that the organization must address and include:

- Making the organizational adjustments to the final outcomes from the core review process including changes coming out of Bill 79, amendments to the *Columbia Basin Trust Act* and consolidation of the power activities as announced by the Ministry of Energy and Mines. CBT will work to continue its commitment to the residents of the Basin by fulfilling its mandate and operating consistent with the CBMP.
- By developing and implementing a capacity building approach to the Delivery of Benefits program, CBT hopes to increase the effectiveness of meeting Basin residents' priorities.

### **Basin Fund Tensions**

The investment of the Basin Fund has to combine safeguarding the capital while investing in the Basin, with the side effect of stimulating the economy, together with providing an income for the Delivery of Benefits program.

The Board has adopted a *Statement of Investment Policy and Procedure* together with a *Governance of CBT Investments* document under the guidance and assistance of the firm of Watson Wyatt Worldwide.

### **Meeting challenges inherent in our delivery model, mandate and working in a rural region**

The Columbia Basin is a rural region with many small communities. There is a limited amount of accessible information about these communities to assist CBT in identifying and addressing regional and community priorities. CBT has a very broad mandate, increasing its challenges with respect to setting and meeting priorities. It also conducts much of its activities by contracting and/or partnering with a large number of local organizations and agencies, increasing the challenge around accountability.

## **STRATEGIC DIRECTION**

---

Over the three years that CBT has been submitting service plans, the process of choosing at what level to focus our reporting and planning for the Delivery of Benefits has posed serious challenges. This service plan focuses on the few, critical aspects of performance and areas where CBT has a meaningful degree of control, consistent with the principles that have been adopted for public sector reporting in B.C.

The following outlines the goals, objectives, strategies, performance measures and targets for the CBT for the period FY2005-FY2007. These planning components will guide the core strategic elements of the organization, specifically the **Investment Program, Delivery of Benefits, and Corporate Services**. As a relatively young and developing organization with very few resources to commit to building reporting capacity, CBT has tried to become better through learning from its previous service plans. As a result, this year's service plan has focused on a few, critical aspects of performance. In determining goals and objectives, the organization has asked the question of its three strategic elements "why does this element exist in the organization and what role does it play?" The appropriate measures, both quantitative and qualitative, flowed from these decisions and their connection to the goals, objectives and strategies are clearer and more results based. The plan reflects statements of policy, procedure and direction as adopted by CBT's Board of Directors.

STRATEGIC ELEMENT	STRATEGIC GOALS
<b>INVESTMENT PROGRAM</b>	<p><b>Basin Fund Goals:</b></p> <ol style="list-style-type: none"> <li>1. Maximize the expected return of the assets, subject to preserving the real value of the capital over the long-term with an acceptable degree of risk.</li> <li>2. Enhance economic self-sufficiency in the Basin.</li> </ol> <p><b>Legacy Fund Goal:</b></p> <ol style="list-style-type: none"> <li>1. Maximize the expected return of assets, subject to preserving the real value of the legacy capital with a relatively high degree of certainty to generate income to fund the Delivery of Benefits program.</li> </ol>
<b>DELIVERY OF BENEFITS</b>	<ol style="list-style-type: none"> <li>1. Enhance the ability of the CBT to strengthen the social, economic and environmental well-being of the Basin, its residents and communities and promote self-sufficiency.</li> </ol>
<b>CORPORATE SERVICES</b>	<ol style="list-style-type: none"> <li>1. Support and enable CBT board and staff to deliver the investment and delivery of benefits programs effectively.</li> </ol>

## **STRATEGIC AREA 1 – INVESTMENT PROGRAM**

The CBT is a “Government corporation” under both the *Financial Administration Act* and the *Budget Transparency and Accountability Act* and has mandated the governance and management of power related investments through its subsidiary CBT Energy Inc. (CBTE). In January 2004, the Ministry of Energy and Mines announced consolidation of the CBT’s and CPC’s power activities (i.e. the development and management of the joint venture power projects) into a single corporation to be a subsidiary of CBT. The strategic direction including the goals, objectives, strategies and performance measures for CBTE (included in Appendix B, CBTE Service Plan) will be affected by the implementation of the consolidation, scheduled to take place over the next few months. This section of the CBT service plan outlines only the non-power investment goals and objectives.

The goals of the Basin Fund (non-power) investments have not changed appreciably from previous service plans. However, in previous years, work on investment policy, which incorporated performance management, was in development. That work is now complete and the performance management elements are reflected here.

### **Goals:**

- To maximize the expected return of the assets, subject to preserving the real value of the capital over the long-term with an acceptable degree of risk.
- Enhance economic self-sufficiency in the Basin (subject to maintaining the real value of the capital over the long-term).

## **OBJECTIVE 1**

*Investment*

*To generate revenue from Basin Fund investments.*

### **Strategies:**

#### **Risk Parameters**

The Board recognizes the greater inherent risk associated with the Basin Fund. Greater risk is expected to come from one or more of the following expected characteristics of the investment opportunities within the Basin Fund at any one point in time:

- Higher operating risks.
- Higher financial risks.
- Greater investment structure complexity.
- Greater liquidity risk.
- Reduced ability to diversify unsystematic risks.

(It is recognized that not all investment opportunities will exhibit the above characteristics.)

#### **Investment Guidelines**

- Given that economic conditions and investment opportunities within the Basin region will primarily drive investment within the Basin Fund, no formal asset allocation guidelines have been established for the Basin Fund. The Investment Manager(s) will, however, seek to diversify investments within the region by asset class, geography (within the Basin), industry and company.
- Investments made within the Basin will have the secondary objective of creating and stimulating economic value and activity over the long term for the benefit of the Basin and its residents.
- The Investment Manager(s) will consider secondary benefits as part of the investment evaluation process only after the investment is considered appropriate based upon the financial due diligence.

#### **Risk Management Strategy:**

1. Performance will be calculated in accordance with Association for Investment Management Research Performance Presentation Standards (“AIMR –PPS”), as amended from time to time.
2. Investments placed in accordance with Board-adopted investment policies and procedures to mitigate risk.
3. Watson Wyatt World Wide will be contracted on an as needed basis to work with CBT’s Investment and Audit Committees to provide advice and guidance for their decision-making processes and to assist in ensuring consistency with CBT’s investment policy.
4. Subject to maintaining the real value of the capital over the long-term, to enhance the economic self-sufficiency of the Basin by strengthening and diversifying the regional economy.
  - a. Making this goal subject to meeting the financial goal mitigates the risks in the Basin Fund tensions.
  - b. It also constitutes a risk management strategy for the risks associated with the regional economy.

<b>Performance Measures</b>	<b>Baseline/Current Year (Benchmark)</b>	<b>FY2005</b>	<b>Targets FY2006</b>	<b>FY2007</b>
Rate of return	Compound return on non-power investments measured over rolling 5 year period of 3.49%. Lower return due to low rate of interest on term deposits and lower than expected return on venture capital investments.	The primary rate of return objective is to achieve a real return of 6% per annum measured over rolling 8-year periods.	The primary rate of return objective is to achieve a real return of 6% per annum measured over rolling 8-year periods.	The primary rate of return objective is to achieve a real return of 6% per annum measured over rolling 8-year periods.

## **STRATEGIC AREA 2 - DELIVERY OF BENEFITS**

Over the three years that CBT has been submitting service plans, the process of choosing at what level to focus our reporting and planning for the Delivery of Benefits program has posed serious challenges. For consistency with B.C. public sector reporting principles, CBT has focused on a few, critical aspects of performance over which CBT has a meaningful degree of control.

### **Goal:**

- To enhance the ability of the CBT to strengthen the social, economic and environmental well-being of the Basin, its residents and communities.

### **OBJECTIVE 1**

*Delivery of Benefits*

***To effectively gain knowledge of, and apply resources to, community, regional and cross-sectoral priorities and issues.***

### **Strategies:**

- Make changes to the program delivery model and the allocation of funding to increase the consistency between the delivery model and the goals and objectives of the Delivery of Benefits program.
- Change staff job descriptions, work priorities and/or other operational processes required to increase consistency between staff work and the goal and objective of the Delivery of Benefits program.
- Develop methods of gathering the information required to support achieving the goal and objective of the Delivery of Benefits program.

### **Risk Management Strategies:**

- Provide staff training to increase effectiveness in balancing residents' expectations with constraints of funding levels and addressing the issue of fairness within a capacity building model.

- Inform and educate Basin residents to increase knowledge and awareness of CBT’s funding limitations and the benefits of a community capacity building model of delivery.

<b>Performance Measures</b>	<b>Baseline/Current Year (Benchmark)</b>	<b>FY2005</b>	<b>Targets FY2006</b>	<b>FY2007</b>
Residents rate the consistency between CBT delivery of benefits funding decisions and Columbia Basin Management Plan and Board priorities as measured by: <ul style="list-style-type: none"> <li>▪ annual response to staff from community forums/focus groups</li> <li>▪ analysis of responses from:               <ul style="list-style-type: none"> <li>-comment section of website</li> <li>-feedback from Report to Residents</li> </ul> </li> <li>▪ evaluation information from initiatives</li> </ul>	Since this is a new measure there are no internal benchmarks and at this time neither external benchmarks nor baselines have been established.	<ol style="list-style-type: none"> <li>1. Strategies undertaken.</li> <li>2. Data collection methods established.</li> </ol>	<ol style="list-style-type: none"> <li>1. Baseline rate of consistency established.</li> <li>2. Changes made to future priorities and/or funding decisions based on information coming out of performance measures and reported publicly.</li> </ol>	<ol style="list-style-type: none"> <li>1. Rate increased by 2% from baseline.</li> <li>2. Changes made to future priorities and/or funding decisions based on information coming out of performance measures and reported publicly.</li> </ol>

## **OBJECTIVE 2**

*Delivery of Benefits*

*To ensure effectiveness in the delivery approaches used in the delivery of benefits program.*

### **Strategies:**

- Build effective relationships with individuals, communities, groups and organizations in the Basin.
- Develop delivery processes to ensure that CBT is effectively engaged in Basin communities and the issues of the residents of the Basin.
- Develop application, decision-making and reporting processes and procedures that are efficient and meet the needs of grantees.
- Develop and implement processes and procedures to increase the ability of grantees to determine and report on the results of their projects.

### **Risk Management Strategies:**

- Provide staff training to increase effectiveness in CBT facilitation roles and its need to balance residents’ expectations with constraints of funding levels and addressing the issue of fairness within a capacity building model.
- Inform and educate Basin residents to increase knowledge and awareness of CBT’s capacity building model of delivery, which will provide benefits beyond funding.

<b>Performance Measures</b>	<b>Baseline/Current Year (Benchmark)</b>	<b>FY2005</b>	<b>Targets FY2006</b>	<b>FY2007</b>
1. Effectiveness rating on CBT's delivery processes by those CBT works with through the delivery of benefits program.	1. Baseline to be established by first survey.	1. Develop survey instruments to measure effective delivery of CBT delivery of benefits program.	1. Baseline established with results of first survey.	1. 5% increase in effectiveness rating over baseline.
2. Rating of perceptions of grantees on survey.	2. Center for Effective Philanthropy (CEP) rating average of surveyed grantees <sup>1</sup> .	2. Explore and budget for ways of participating in a grantee perception survey.	2. Changes made to delivery processes based on survey results.	2. Changes made to delivery process based on survey results.
3. Proportion of grantees with project results consistent with CBT policies and procedures reported.	3. Procedures are currently being developed so no current year or comparative data available.	3. Explore and budget for ways of participating in a grantee perception survey.	3. Average rating compared to other Foundations' performance as measured by CEP Grantee Perception Report (CEP Grantee Perception Report Average Rating).	3. CEP Grantee Perception Report Average Rating.

<sup>1</sup> The plan is to explore participating in CEP grantee perception survey. CEP conducts a survey of grantees perceptions of work of the Foundation for a large number of Foundations in the U.S. and provides an analysis of the responses, which allows Foundations to compare the perceptions of their grantees to those of other foundations. The work done by CBT in the grant making function of the Delivery of Benefits is similar enough to the work of Foundations that these results can be used as a benchmark. CBT would participate in the process once every five years and compare its results with those of the other participating organizations. In the intervening years CBT would conduct its own grantee survey and make comparisons to the previous year's results.

## **STRATEGIC AREA 3 - CORPORATE SERVICES**

In keeping with Government Reporting Principles of focus on the few critical aspects of performance, the goal and objective for the Corporate Services Strategic Area focuses on its essential function for the organization. As this function is the provision of services, significant work needs to be done to develop the tools necessary to measure service levels and to obtain information regarding effectiveness. Once these tools are developed and implemented, CBT's service areas should have good quality information regarding their effectiveness rating.



**Goal:**

- To support and enable CBT board and staff to deliver the investment and delivery of benefits programs effectively.

<b>OBJECTIVE 1</b> <i>Corporate Services</i>	<b><i>To ensure effective provision of support services.</i></b>
---	--

**Strategies:**

- Develop service area reviews and implement annually.
- Make changes to the provision of services based on information coming out of the reviews.
- Work with CPC, the CBT board and the board of the new power subsidiary to ensure successful implementation of consolidation of CBT’s and CPC’s power activities.

**Risk Management Strategies:**

- Develop effective change management strategies by:
  - planning sessions to ensure strong and consistent strategic direction.
  - developing strong internal communications processes.
  - developing effective information gathering and dissemination processes.
  - maintaining strong relationships with Basin residents, organizations and agencies.
- Adhere to investment policy to ensure sound investment management.
- Provide effective staff training particularly around capacity building and sound contract management.

<b>Performance Measures</b>	<b>Baseline/Current Year (Benchmark)</b>	<b>FY2005</b>	<b>Targets FY2006</b>	<b>FY2007</b>
Proportion of staff rating each service area service provision as effective.	Since this is a new measure, there are no internal benchmarks and at this time neither external benchmarks nor baselines have been established.	1. Data collection methods associated with each service area review established.	1. Overall baseline established.  2. Baselines for each service area established.  3. Changes made based on information coming out of the service area review for each service area.	1. Increase of 2% on overall and each service area baseline.  2. Changes made based on information coming out of the service area review for each service area.

# ALIGNMENT TO THE GOVERNMENT'S STRATEGIC PLAN

---

The CBT is accountable to the residents of the Basin. However, as a regional Crown Corporation funded through a financial agreement with the Province the CBT ensures that its Service Plan is consistent with the Province's Strategic Plan.

Because of the CBT's regional focus, its Vision for the Basin is a microcosm of, and therefore directly aligned with, the Vision for the Province.

The Provincial Strategic Plan three primary goals areas include:

1. A strong and vibrant provincial economy.
2. A supportive social infrastructure.
3. Safe, healthy communities and a sustainable environment.

The following outlines the consistency between the goals of the CBT and those of the Province:

PROVINCIAL STRATEGIC GOAL	CORRESPONDING CBT GOALS
<p><b>A strong and vibrant provincial economy</b></p>	<p><b>Basin Fund:</b> Maximize the expected return of the assets, subject to preserving the real value of the capital over the long-term with an acceptable degree of risk.</p> <p><b>Legacy Fund:</b> Maximize the expected return of assets, subject to preserving the real value of the legacy capital with a relatively high degree of certainty to generate income to fund the Basin Fund and the Delivery of Benefits program.</p> <p>Enhance economic self-sufficiency in the Basin.</p>
<p><b>A supportive social infrastructure</b></p>	<p>The goal of the delivery of benefits strategic area is to enhance the ability of the CBT to strengthen the social, economic and environmental well-being of the Basin, its residents and communities.</p>
<p><b>Safe, healthy communities and a sustainable environment</b></p>	<p>The goal of the delivery of benefits strategic area is to enhance the ability of the CBT to strengthen the social, economic and environmental well-being of the Basin, its residents and communities.</p>

# SUMMARY FINANCIAL OUTLOOK

	<b>2003/04</b>	<b>2004/05</b>	<b>2005/06</b>	<b>2006/07</b>
	<b>Forecast</b>	<b>Forecast</b>	<b>Forecast</b>	<b>Forecast</b>
<b>REVENUES</b>				
Deposits and Securities	794,000	623,000	574,000	520,000
Business Loans	1,219,000	1,361,000	1,454,000	2,516,000
Real Estate	277,000	458,000	668,000	758,000
Business interests	5,000	5,000	1,200,000	1,450,000
Power project	7,851,000	6,589,000	7,532,000	11,561,000
Provincial government contribution to operations	2,000,000	2,000,000	2,000,000	2,000,000
<b>Total Revenues</b>	<b>12,146,000</b>	<b>11,036,000</b>	<b>13,428,000</b>	<b>18,805,000</b>
<b>EXPENDITURES</b>				
Corporate operations	3,500,000	3,800,000	4,100,000	4,200,000
Investment write-down	2,000,000	-	-	-
Delivery of Benefits	3,750,000	5,000,000	5,000,000	7,000,000
<b>Total Expenditures</b>	<b>9,250,000</b>	<b>8,800,000</b>	<b>9,100,000</b>	<b>11,200,000</b>
<b>NET INCOME</b>	<b>2,896,000</b>	<b>2,236,000</b>	<b>4,328,000</b>	<b>7,605,000</b>

<b>Key Assumptions</b>	<b>Forecast Risks and Sensitivities</b>
1. Deposits and securities income: - 3.0% per annum on year end balance	Fluctuating interest rates have a direct effect on the income of deposits and securities, business loan income, and power project income.
2. Business loan income: - 6.5% per annum after providing for a capital maintenance provision of 2%	Power project borrowing rate is affected by fluctuations in interest rates.
3. Power project short-term borrowing rate is 5.3%.	An increase or decrease in power project rates could increase or reduce power project revenues.
4. Power projects: - Interest rate on short term investments is 2 - 3% (Fiscal Agency Agreement borrowing rate) Forecasts do not include Waneta Upgrades, Waneta Expansion, or other uncommitted projects.	
5. Assumptions underlying these forecasts may change as a result of the outcomes of the implementation of the consolidation of power activities.	

## Capital Expenditure Schedule

*Fiscal 2004-2007*

**Consolidated**

**Capital Spending**

**(Unaudited, in thousands)**

Please note that the figures in the Capital Expenditure Schedule reflect CBT's 50 per cent share in the joint venture power projects.

	<b>Forecast FY2004</b>	<b>Forecast FY2005</b>	<b>Forecast FY2006</b>	<b>Forecast FY2007</b>
<b>ARROW LAKES POWER CORPORATION</b>				
Arrow Lakes Generating Station	2,348	485	319	276
<b>BRILLIANT EXPANSION POWER CORPORATION</b>				
Brilliant Expansion	37,340	40,433	11,049	8,444
<b>POWER PROJECT PLANNING</b>				
Waneta Expansion	900	2,891	2,745	2,632
Other Projects	65	65	65	65
General Power Project Planning	450	200	200	200
<b>COLUMBIA BASIN POWER COMPANY</b>				
Brilliant Sustaining Capital/Upgrades	2,168	760	1,490	2,952
Brilliant Terminal Station (BTS)	12,447	-	-	-
<b>COLUMBIA BASIN TRUST CORPORATE</b>				
Computers, furniture, equipment	200	200	200	200
<b>TOTAL</b>	<b>55,918</b>	<b>45,034</b>	<b>16,068</b>	<b>14,769</b>

### Arrow Lakes Generating Station

The Arrow Lakes Generating Station will produce approximately 185 megawatts of power capacity and deliver approximately 760 gigawatt hours of electricity annually. Construction was effectively completed in FY2002. The second of two generating units at this plant was commissioned in May 2002.

### Brilliant Expansion

The proposed \$205M Brilliant Expansion project will see the construction of a second powerhouse at the Brilliant Dam. This project will provide approximately 120 megawatts of power capacity. Proposals were received from two competing teams in July 2002. The evaluation process resulted in the Brilliant Expansion Consortium (BEC) formed by Skanska/Chant/SNC Lavalin being chosen as the preferred bidder. Construction of the project began in April 2003.

## **Waneta Expansion**

Using the expansion rights currently owned by CBT/CPC, the joint venturers plan to build a 380-megawatt facility below the Waneta Dam. It is projected that construction of the Waneta Expansion project will take place over a four-year period with the construction costs estimated to be approximately \$300M.

# Appendix A

## Organization Structure

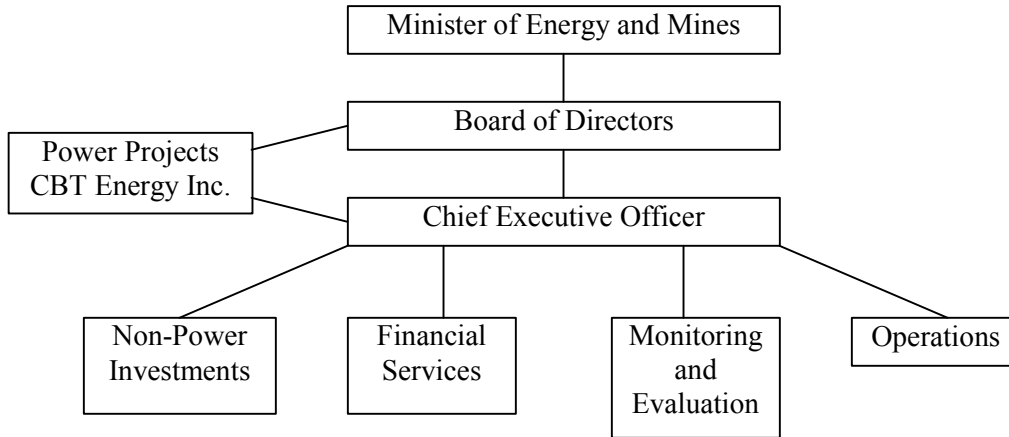

## Organization Structure (Post-Consolidation)

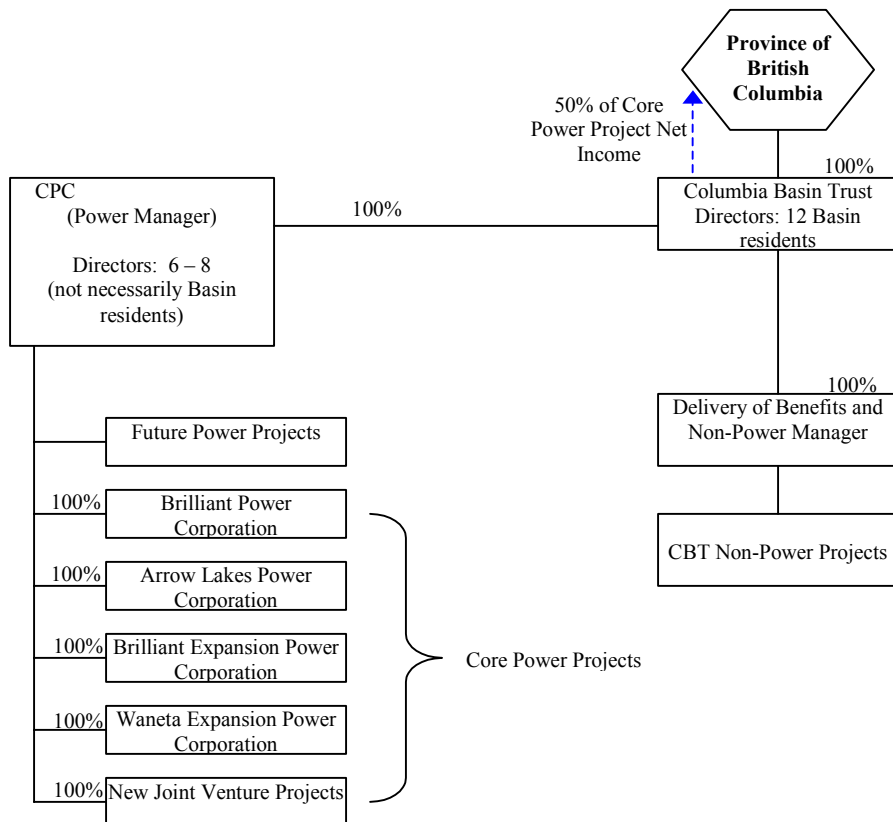

## Functional Areas

<b>Financial Services</b>	<b>Non-Power Investments</b>	<b>Power Projects (CBTE)</b>	<b>Monitoring and Evaluation</b>	<b>Operations</b>
<ul style="list-style-type: none"> <li>• Financial management and reporting.</li> <li>• Oversees accounting, budgeting and payroll</li> <li>• Risk management and assessment</li> <li>• Compliance with legal and tax regulations</li> </ul>	<ul style="list-style-type: none"> <li>• Basin Fund of \$52M endowment capital invested in region to best of private practice standards.</li> <li>• Basin Fund kept intact.</li> <li>• Income provided to delivery of benefits program</li> </ul>	<ul style="list-style-type: none"> <li>• Works in joint venture partnership with the Province of B.C. to build, upgrade and expand and maintain power projects owned by the joint venture.</li> <li>• Provides income to delivery of benefits program</li> </ul>	<ul style="list-style-type: none"> <li>• Design and build planning frameworks and establish and carry out monitoring and evaluation processes for delivery of benefits and corporate areas of responsibility.</li> </ul>	<ul style="list-style-type: none"> <li>• Oversees delivery of benefits program to the region to enhance social, environmental and economic well-being in the Basin.</li> <li>• Provides administrative services, staff recruitment, compensation, job evaluation, occupational health and safety.</li> <li>• Oversees corporate communications and information technology functions.</li> </ul>

## **Appendix B - CBT Energy Inc. Service Plan 2005 –2007**

### **OVERVIEW**

CBT Energy Inc. (CBTE) is a wholly owned subsidiary of Columbia Basin Trust (CBT), and was incorporated on September 7, 2000 under the *Canada Business Corporations Act*. According to the 1995 Financial Agreement with the Province, both the CBT and CPC would each receive \$250M over ten years and the Brilliant and Waneta Expansion Rights (\$26M each), to invest in the Keenleyside (now Arrow Lakes Generating Station), Brilliant Expansion and Waneta Expansion power projects. The CBT and CPC (a Crown Corporation and agent of the Province) became joint venture partners in 1996, with CPC contracted to act as the Manager. Since then, the joint venturers have purchased the Brilliant dam from Teck Cominco and have completed significant upgrades to the Brilliant dam facility. The joint venture partners have also completed construction of the Arrow Lakes Generating Station (“ALGS”), have constructed a new substation and have commenced construction on the Brilliant Expansion Project.

In order to effectively manage CBT’s fifty per cent interests in the joint venture power projects, in part by securing the appropriate expertise to participate in the energy industry, CBT incorporated CBTE in 2000. Section 4 of the *Columbia Basin Trust Act* states that CBT is “to invest, spend and otherwise manage the regional allocation and the corporation's other assets, including any assets that may be transferred to it, for the ongoing economic, environmental and social benefit of the region.” CBTE represents the mission and vision of the CBT in the energy area. Through CBTE’s oversight of the Manager, CBT is assured that income will be returned from its assets to fund the benefits described in its enabling legislation.

CBTE’s Board of Directors is composed of CBT representatives and energy industry experts, who ensure that rapidly evolving market conditions are taken into account when business planning. In addition, the CBTE Board of Directors guarantees that CBT uses diverse views to evaluate the opportunities and risks associated with power project development, investment and management.

In January 2004, the Ministry of Energy and Mines announced changes to the existing joint venture power project delivery structure that are intended to result in savings for both the CBT and the Province through the simplification of the existing structure. The changes include:

- Consolidation of joint ventures between CBT and CPC into a single, 100 per cent CBT-owned subsidiary responsible for the development and management of the power projects.
- Creation of an expert board of directors charged with governance of the new CBT subsidiary.
- CBT appointment of the majority of the expert board of directors of the new CBT subsidiary.

CBT and the Province will continue to equally share in the income from the power projects. The new subsidiary will be charged with maximizing the value of and income from the power projects. At the time of writing of this Service Plan, the implementation of these changes was in the very early stages. In this Service Plan, CBTE has included descriptions of its current vision, mission, values, goal and objectives with the understanding that subsequent Service Plans will reflect the consolidation of power activities between CBT and CPC and will contain full disclosure of power project development and operations currently found in CPC's Service Plan.

Several modifications to the CBT Energy (“CBTE”) section of the *Columbia Basin Trust 2004 – 2006 Service Plan* have been made. These changes reflect CBTE’s commitment to follow the service plan guidelines produced by the Province and to articulate CBTE’s public purpose and the links between its goals and those of its shareholder, CBT. Minor changes have been made to the Overview, but CBTE’s



Goals, Strategies and Performance Measures are the chief sections that see significant change. In future plans, this section of the Service Plan will incorporate all areas of power planning operations.

### **Vision**

In the future, CBTE envisions a pursuit of development options in the energy industry complementary to its joint venture power projects, including the provision of support services to large energy users, other utilities and other independent power producers. Given the recent completion of ALGS and the start-up of construction on the Brilliant Expansion Project, CBTE's focus will shift from power project development to include operation, trading and management.

### **Mission**

CBTE develops and manages energy and power related projects, including those identified in the CBT's Financial Agreement with the Province of B.C., for the purposes of creating long-term income for the CBT, which delivers social, economic and environmental benefits to the residents of the Columbia Basin.

### **Values**

The following values guide CBTE's operations:

- Adherence to the best of private sector practices.
- Accountability for its actions and its results to its shareholder.
- Adherence to the mission, vision, goals and objectives of its shareholder in any actions undertaken.
- Dynamic and inclusive planning processes, taking market trends and developments into account.
- Open avenues of communication with partners and associates.

## **PLANNING CONTEXT AND KEY STRATEGIC ISSUES**

In the *Columbia Basin Trust Service Plan 2004 - 2006*, CBTE cited several potential risks and opportunities to its investments, including perceived lack of transmission access on the B.C. and U.S. sides of the border, potential new property tax costs, regulatory challenges and the BC Hydro Water Use Planning processes. Many of these same risks and opportunities still exist. CBTE shall continue to work independently and with its joint venture partner to address these risks and opportunities in a timely manner.

### **Market and Regulatory**

The implementation of the provincial energy policy and specifically of the Heritage Contract, Stepped Rates and Transmission Access Principles will significantly affect the electricity market in B.C., including CBTE's access to transmission and therefore its ability to sell the energy produced at its facilities. CBTE participated in the regulatory process leading up to the BCUC's recommendations to the Province on this matter. With the release of the Province's response to the BCUC recommendations, CBTE will determine whether or not further participation in any upcoming regulatory proceedings is necessary.

Like B.C., North America's energy industry also continues to evolve. The Federal Energy Regulatory Commission is encouraging the formation of Regional Transmission Organizations which may result in greater access to the wholesale electricity market and will increase the range of potential purchasers of CBTE electricity.

Fortis Inc. recently acquired Aquila Networks Canada. Aquila Networks Canada currently purchases the power produced at the Brilliant Dam, and operates the Brilliant Dam and ALGS on behalf of the joint venture partners. Fortis Inc.'s intentions with regard to its newly acquired assets and responsibilities have the potential to affect CBTE's joint venture power projects.

### **Environment**

BC Hydro's Water Use Plans for the Duncan Dam and the Columbia River system could result in modifications to the operating regimes of BC Hydro's facilities on those river systems. Any modifications to the operating regimes of BC Hydro's facilities have the potential to impact the amount of electricity CBTE may produce at its own facilities. The Columbia River Water Use Plan is nearing completion. To ensure that its generation interests are protected, CBTE monitors both processes, and is working with the Manager to represent the joint ventures to the decision-making bodies of the Water Use Plans.

### **Financial**

Together with its joint venture partner, CBTE must, on occasion, raise financing for the construction of its generating assets. As interest rates are prone to fluctuation, CBTE strives to avoid debilitating its ability to distribute income to its shareholder by performing due diligence on all possible financial transactions and working with CPC to secure financing in the long-term interests of the joint venture partners.

## **STRATEGIC DIRECTION**

---

The following outlines the goals, objectives, strategies, performance measures and targets for the CBTE for the period FY2005-FY2007. In this service plan CBTE, like CBT, has focused on a few, critical aspects of performance by asking the question of "why does this unit exist in the organization and what role does it play?" The appropriate measures, both quantitative and qualitative, flowed from this and the connection to the goals, objectives and strategies are clearer than in previous service plans.

### **GOAL:**

- Increase the amount of dividends distributed to the CBT.

### **OBJECTIVE 1:**

- Earn increasing levels of income through power sales from the existing joint venture power projects.

### **Strategies:**

- Ensure CPC fulfills its duties and responsibilities as Manager of the joint venture power projects.
- Aid the CBT in ensuring a smooth transition to management and development of the joint venture power projects under the new CBT subsidiary.
- Liaise with the Board of Directors of CBT and staff members of CBT when necessary.

**Link to the CBT:** Objective 1 allows CBT to attain its goals of maximizing the expected return of the Legacy Fund assets (which are composed of CBT's interests in the joint venture power projects) and of funding the Basin Fund and the Delivery of Benefits program.

**OBJECTIVE 2:**

- Preserve the real value of the joint venture power projects.

**Strategies:**

- Monitor energy industry developments in B.C. and North America and participate in the development of the energy industry when deemed necessary by the CBTE Board.
- CBTE will:
  - Review and analyze market conditions on an ongoing basis.
  - Recalibrate CBTE forward electricity price curve on a regular basis.
  - Ensure CBTE Board is aware of all energy industry developments and assesses the significance of such developments in the context of the joint venture power projects.
  - Intervene in regulatory proceedings as directed by the CBTE Board.
  - Monitor the viability of alternate energy resources for possible development/investment if such resources are cost competitive.
- Retain sufficient energy expertise for CBTE Board of Directors. (Expertise in areas of power project investment and management, electricity trade and natural gas markets.)

**Link to the CBT:** As outlined in the Planning Context and Key Strategic Issues section, CBTE faces numerous risks as an owner and developer of substantial assets in the energy industry. In order for the CBT to preserve the real value of the Legacy Fund capital with a relatively high degree of certainty, CBTE must monitor and participate in the evolution of the industry within which that same capital is held and must maintain industry expertise on its board of directors.

Performance Measures	Targets		
	2004-2005	2005-2006	2006-2007
Net income in power sales <sup>1</sup>	\$6.6M in net income from Brilliant Dam and ALGS power sales.	\$7.5M in net income from Brilliant Dam and ALGS power sales.	\$11.6M in net income from Brilliant Dam, ALGS and Brilliant Expansion Project power sales.

**Alignment with Government’s Strategic Plan**

The *British Columbia Government Strategic Plan 2003/2004 – 2005/2006* sets out three main goals – a strong and vibrant provincial economy, a supportive social fabric and safe, healthy communities and a sustainable environment. CBTE’s success will clearly aid the Province in attaining its goals over the next three fiscal years.

Affordable and reliable electricity is an integral aspect of the thriving private sector economy the Province intends to attain for its citizens. With the completion of ALGS in 2002 and the construction of the Brilliant Expansion Project, CBTE generates the low-cost power to fuel economic growth in the technological and industrial sectors. Affordable power will aid in the attraction of businesses participating in these sectors to B.C.

Several aspects of the joint venture power projects support the Province’s goal of maintaining a sustainable environment. CBTE produces electricity using a renewable resource.<sup>2</sup> ALGS and the

<sup>1</sup> The targets for 2004-2005 and 2005-2006 have changed from the *Columbia Basin Trust Service Plan 2004 - 2006* as a result of periodic updates to financial forecasts.

<sup>2</sup> *Energy for our Future: A Plan for BC* defines renewable resources as “sources of energy that are inherently self-renewing, such as water power, solar energy, wind energy, tidal energy, geothermal energy, wood residue energy, and energy from municipal waste.” (p. 41)

Brilliant Expansion Project both make use of existing water storage and reduce the amount of water spilled at the original dam facilities. The Brilliant Expansion Project is scheduled for completion in August 2006, and its completion will aid the Province in meeting its target of securing new electricity supply from environmentally responsible sources.<sup>3</sup>

CBTE further supports the Province's goal of a supportive social fabric by generating the income the CBT uses to fund social, environmental and economic programs for the residents of the Columbia Basin.

---

<sup>3</sup> The *British Columbia Strategic Plan 2003/04 – 2005/06* states that B.C. will have sustainable resources, measured in the amount of electricity produced from environmentally responsible sources. (p. 20)